

MARCUS KNAUER

CURRENT LIVE RIG SETUP AS OF 2017 FALL

PICTUREOFSOUND.COM

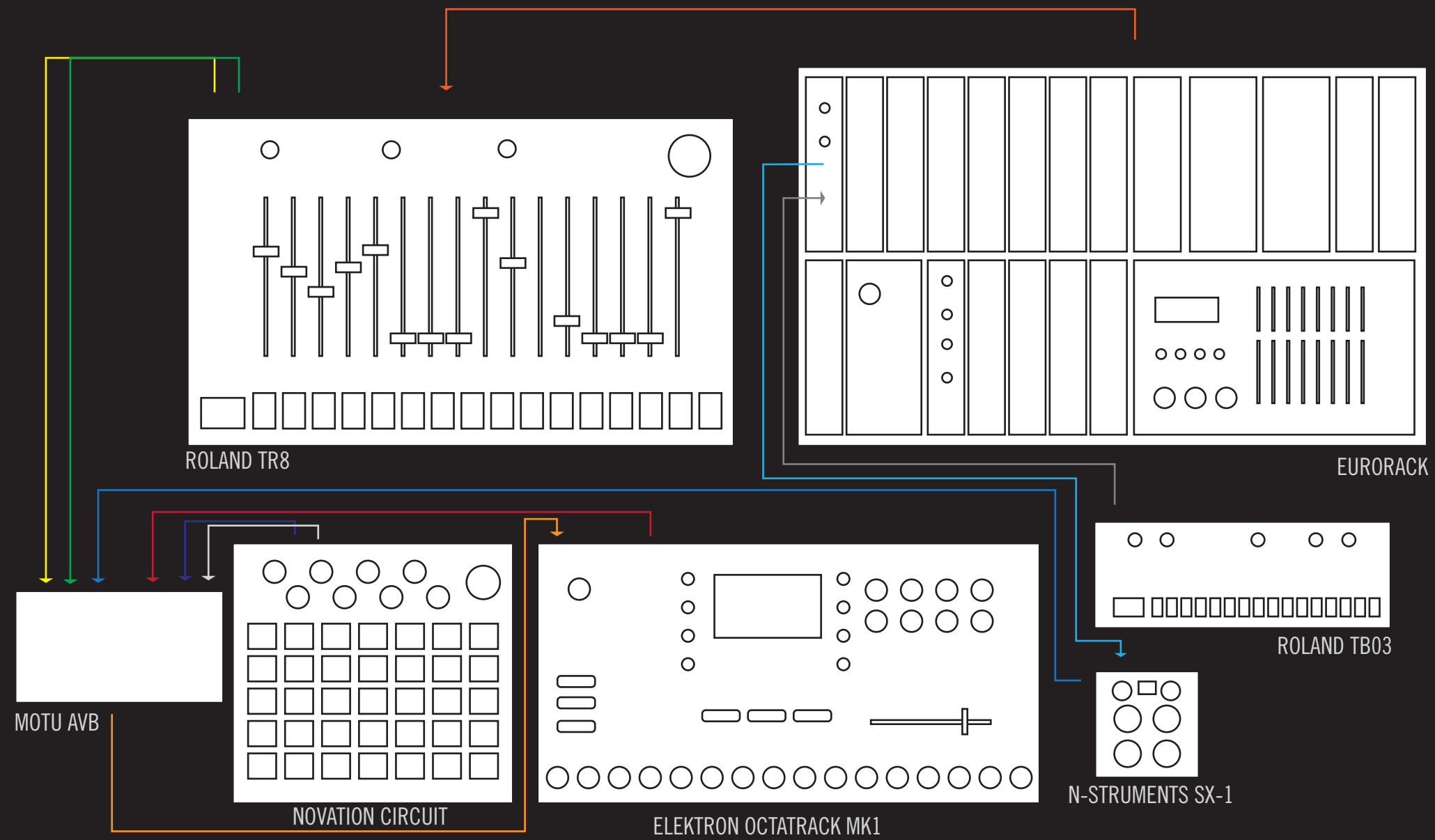

ELEKTRON OCTATRACK MK1, ROLAND TR8, NOVATION CIRCUIT, ROLAND TB3, N-STRUMENTS SX-1, MOTU AVB, EURORACK 80HP

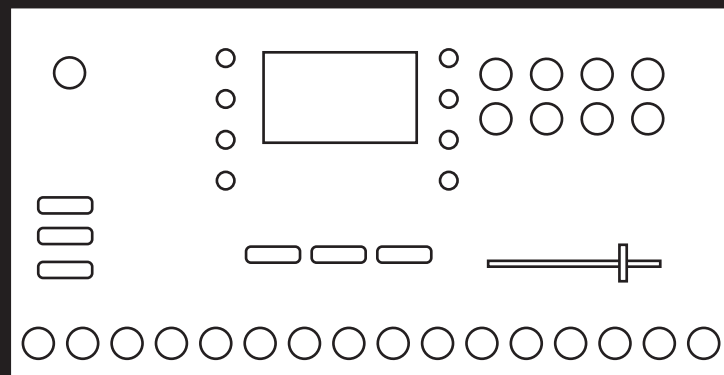

ELEKTRON OCTATRACK MK1

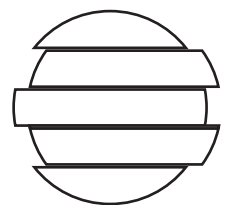

OCTATRACK IS MASTER CLOCK AND THE HUB OF THE PERFORMANCE

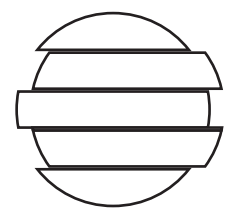
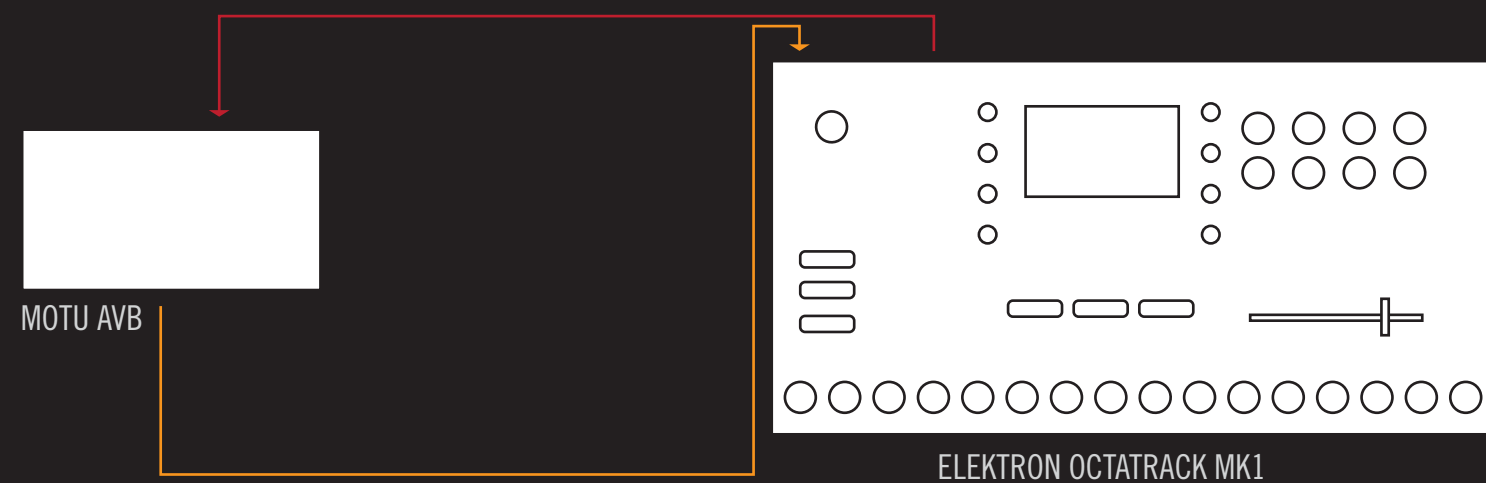

ALL INSTRUMENTS ARE ROUTED TO THE MOTU AVB AND MIXED IN THE MOTU VIRTUAL MIXER
FROM THE MIXER SOUNDS ROUTED INTO THE OCTATRACK INPUTS
THE OCTATRACK MAIN OUTS RUN BACK TO THE MOTU FOR FINAL COMPRESSION AND LIMITING AND THEN TO FOH

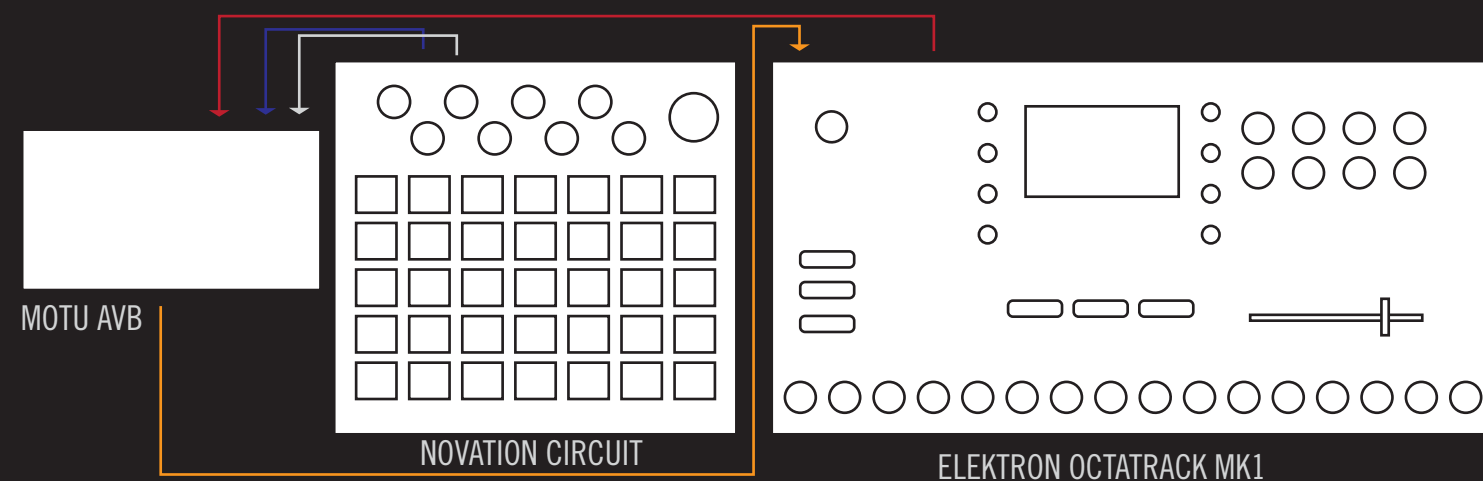

NOVATION CIRCUIT IS USED FOR CAPTURING LIVE SYNTH PARTS OR PLAY BACK OF PREPROGRAMMED SYNTH/DRUM PARTS
OUTPUT IS COMPRESSED AND EQ'D IN THE MOTU THEN RUNS INTO INPUTS A/B OF THE OCTATRACK AND ASSIGNED TO TRACK 6

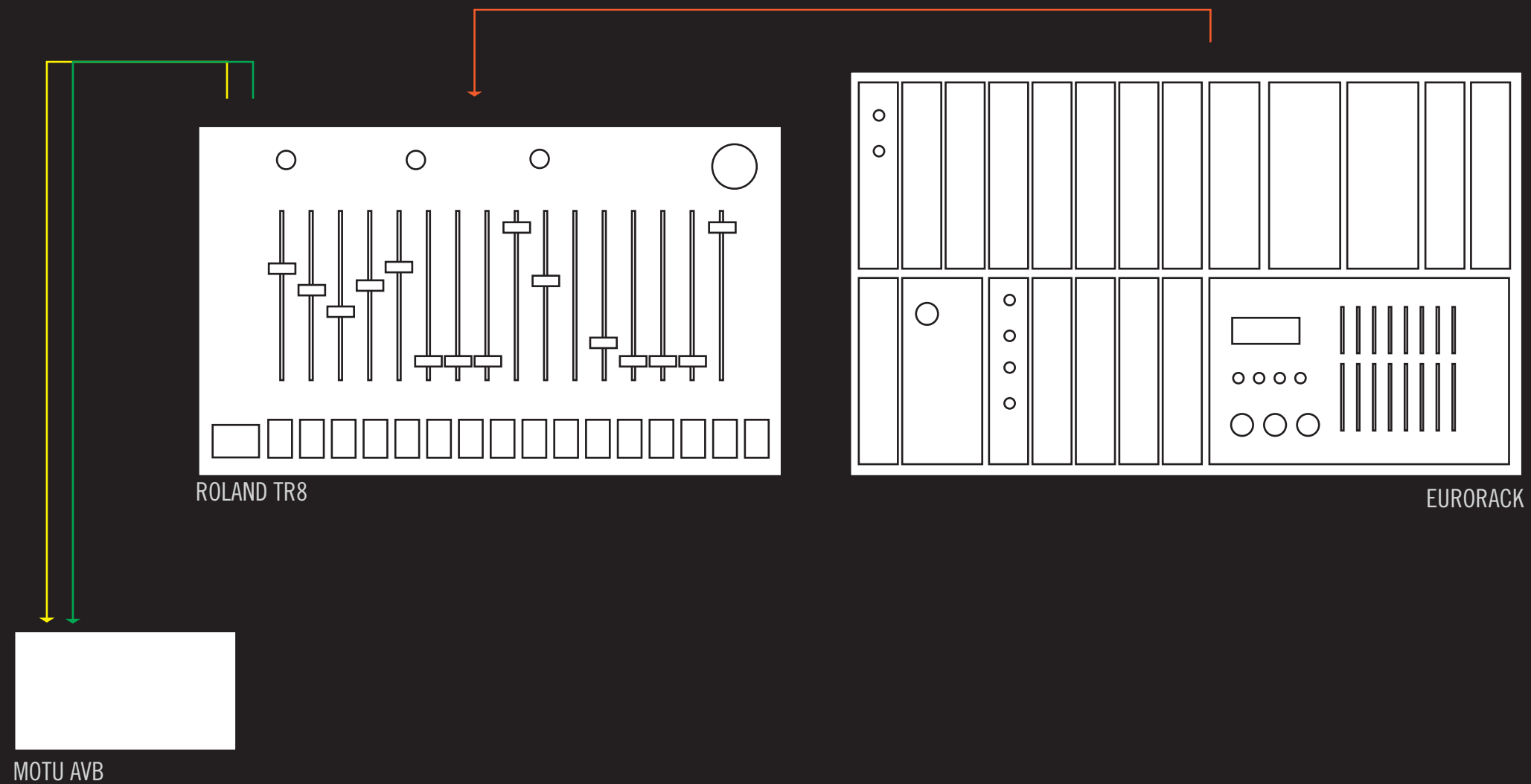

AN ANALOG ORDINANCE NOISE OSCILLATOR RUNS INTO A DIRT FILTER AND OUT TO THE TR8 SIDECCHAIN INPUT
 THIS ALLOWS ME TO USE THE STEP SEQUENCER OF THE TR8 TO MAKE SOME VERY NOISY SYNTH LINES
 REVERB AND COMPRESSION ARE ADDED IN THE MOTU

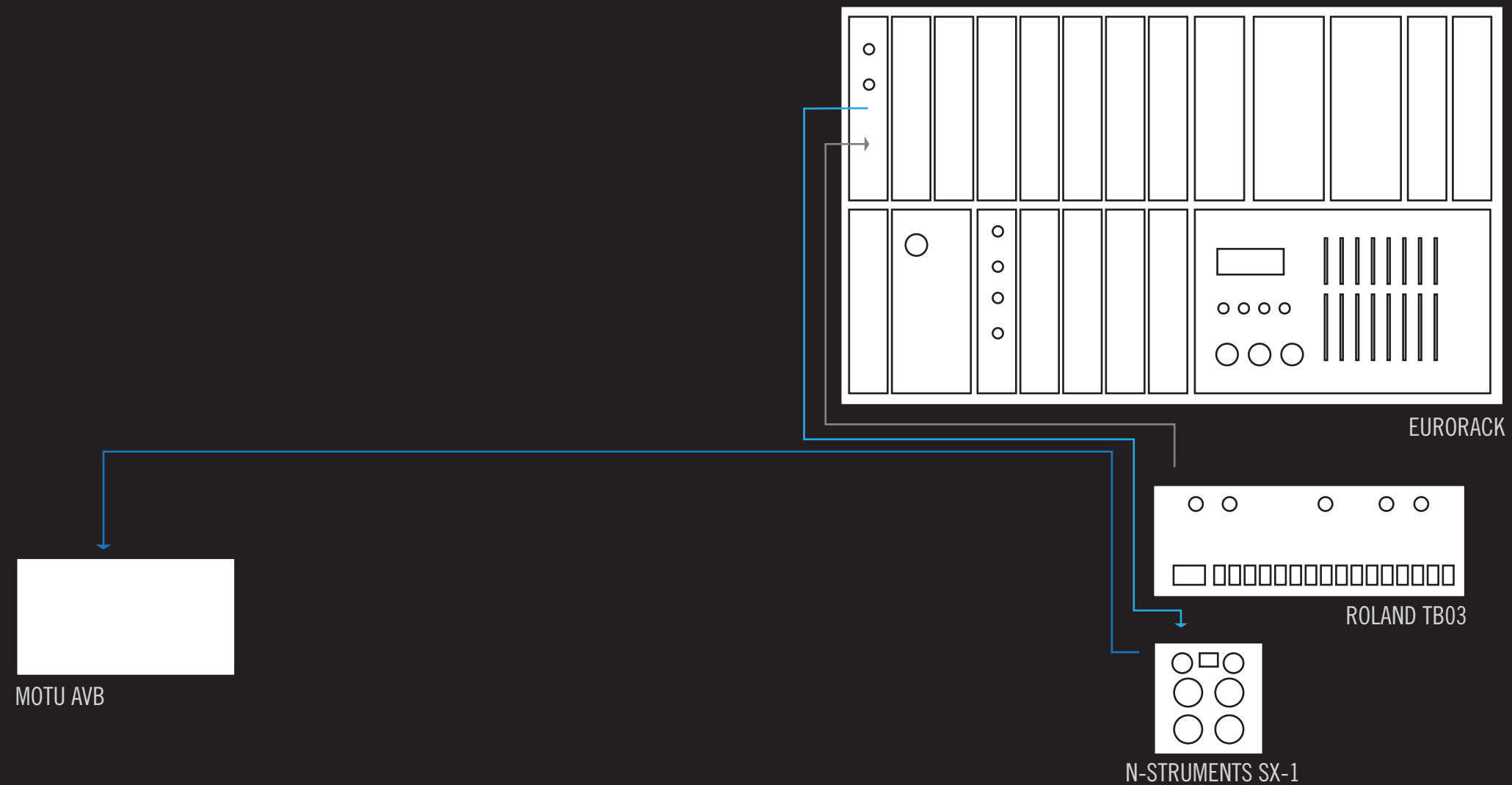

THE TB3 RUNS INTO THE EURO RACK MIXER. THE TB3 SEQUENCER DRIVES A PITTSBURGH DNA OSCILLATOR. AN INTELLIJEL METROPOLIS DRIVES A UBRAIDS. MIXER OUT RUNS TO THE NSTRUMENTS SX-1 EFFECTS BOX THE SX1 IS ROUTED TO THE MOTU FOR COMPRESSION AND LIMITING. MOTU FEEDS INPUT C OF THE OCTATRACK

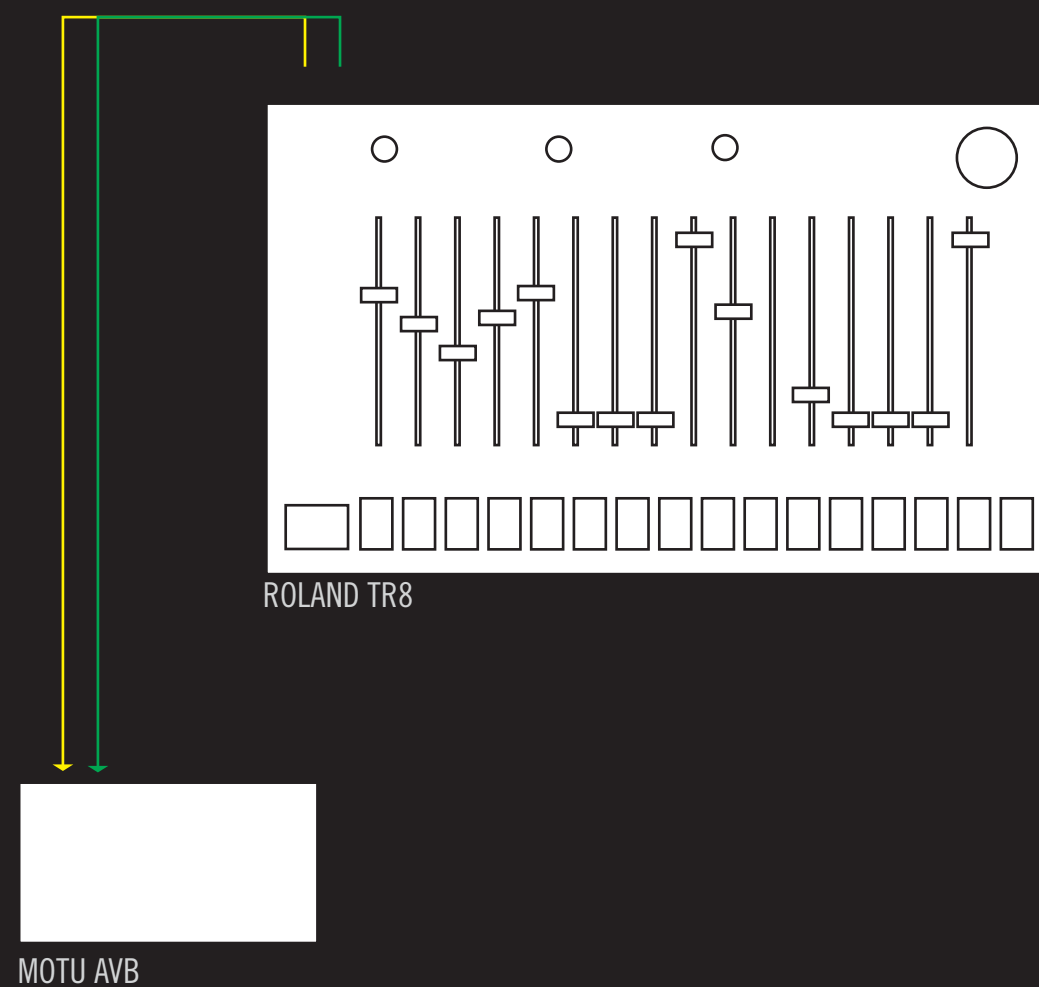

ROLAND TR8 RUNS TO THE MOTU AND IS ASSIGNED TO INPUT D OF THE OCTATRACK. THE TR8 IS USED FOR 909 HATS, CYMBALS, AND PERCUSSION

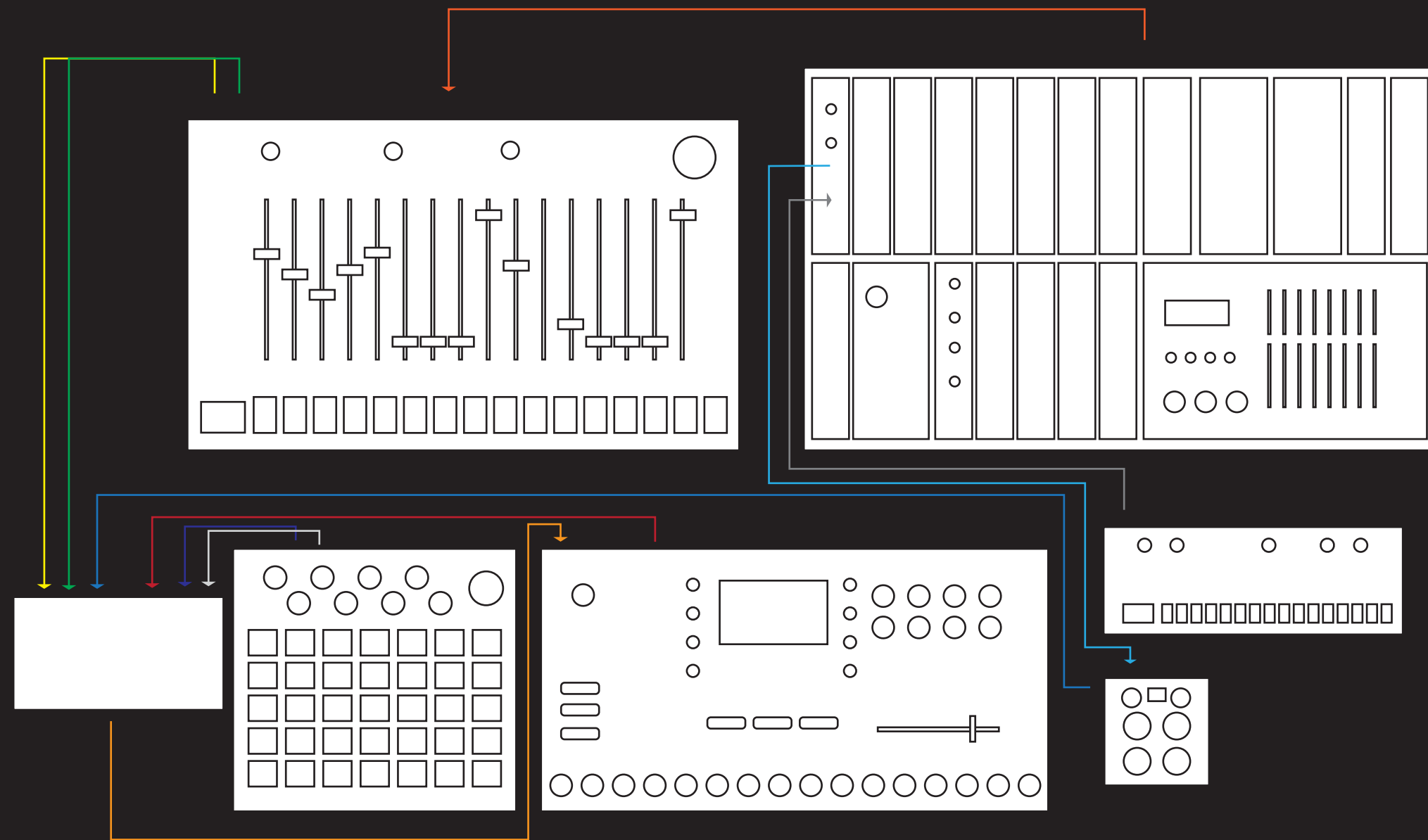

TYPICAL SONG PERFORMANCE: THE OCTATRACK RUNS THE BOTTOM END (KICK AND BASSLINE), TR8 SUPPLIES THE TOP END, WHILE THE OTHER INSTRUMENTS SUPPLY VARIOUS SYNTH LINES AND SOUNDS. EVERYTHING FROM THE EURORACK IS IMPROVISATIONAL. THE CIRCUIT AND TB3 ALLOW FOR LIVE EDITING AND PLAYING AS WELL.

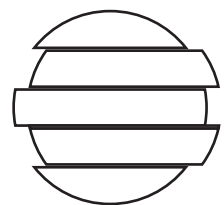
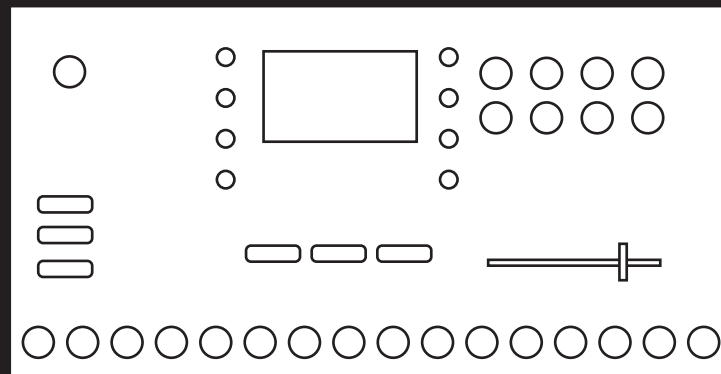

ONCE I'VE BUILT A SONG UP THE OCTATRACK SAMPLES EVERYTHING THAT IS HAPPENING FOR 64 BARS TO TRACK 5. FROM THERE I USE THE "CROSSFADER TRICK" AND MOVE TO A NEW BANK (SONG). FROM THERE I 'MIX THINGS IN' SIMILAR TO WHAT A DJ DOES WITH RECORDS. USING THE CROSSFADER AND BASIC EQ ON TRACK FIVE. FROM THERE THE PROCESS REPEATS FOR EACH NEW "TRACK".

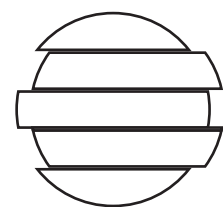
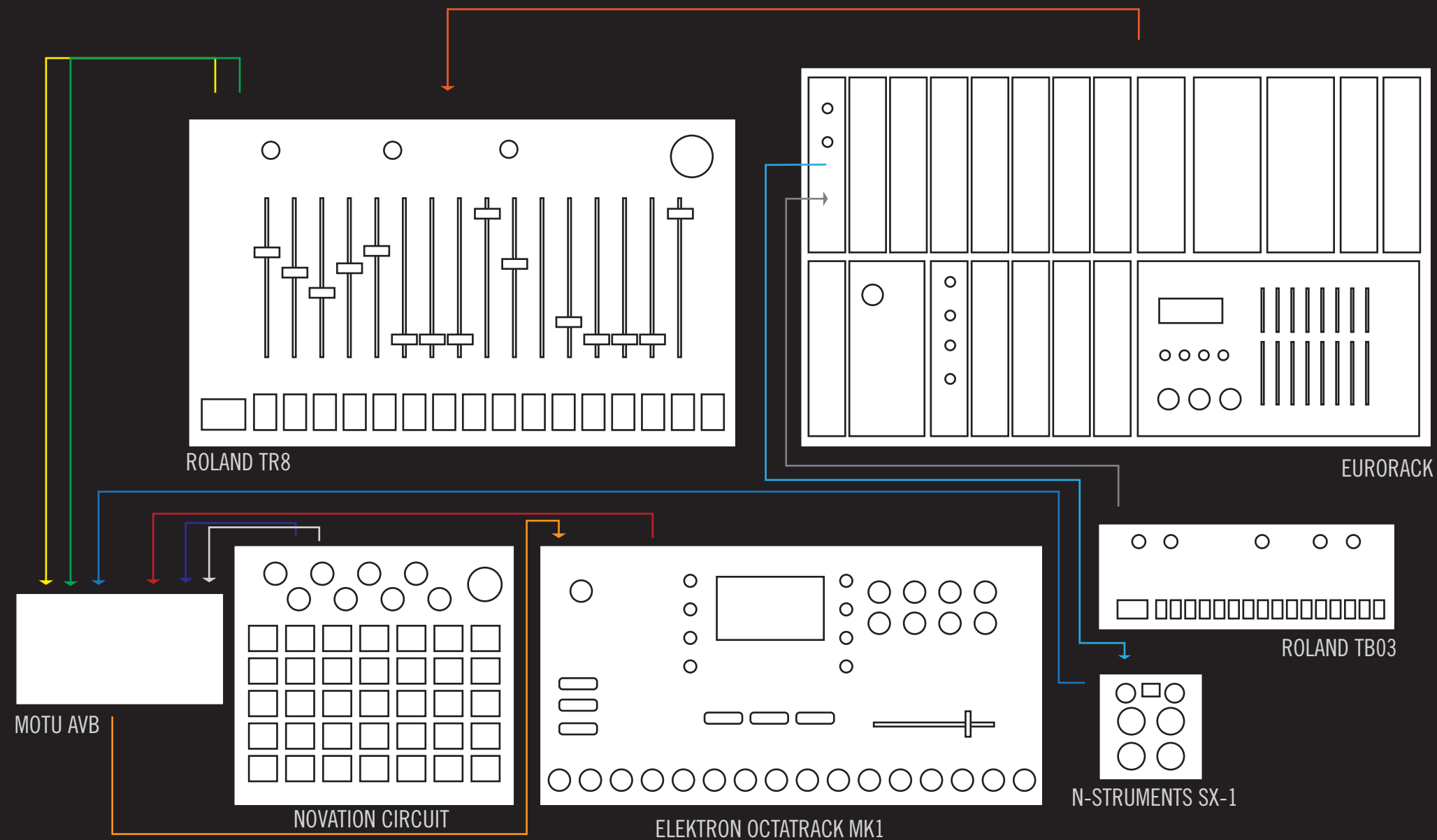

THERE ARE CERTAINLY EASIER WAYS TO ACCOMPLISH WHAT I'M DOING BUT I FEEL THEY DON'T LEAVE ENOUGH ROOM FOR ERROR. THERES A LOT OF THINGS THAT CAN, AND DO, GO WRONG WHEN I'M PLAYING BUT THAT IS WHAT I ENJOY. THE CHALLENGE. THIS IS LIKE RUNNING A ONE MAN BAND, TRYING TO SAMPLE IT ALL, AND THEN MIX IT WITH ANOTHER BAND. IT'S CHAOS WITH RULES. HOW MUSIC SHOULD BE.